

# Nest Boxes *for the* Gippsland Region

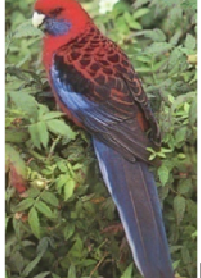

East Gippsland &  
Maffra and District  
**Landcare**  
Networks

This booklet, *Nest Boxes of the Gippsland Region*, was originally compiled by Jessica and Olivia Kurec under guidance of Steve Kurec (Director, Heyfield Treescaping Services Pty. Ltd.).

The booklet was first published in 2009 by the Maffra and District Landcare Network Inc. and formed part of the Network's Biodiversity Outcomes Project.

Funding for this project and the initial booklet publication was supported by the Australian Government's Caring for our Country initiative.

This 2013 reprint with minor text and formatting amendments was a joint initiative between the Maffra and District Landcare Network Inc. and the East Gippsland Landcare Network Inc.

Funding of the reprint was contributed by the Victorian Landcare Grants Program through the Maffra and District Landcare Network Inc. and the East Gippsland Landcare Network Inc.

The Australian Government's Caring for our Country initiative also contributed partial funding towards this reprint.

#### ***What is Landcare?***

Landcare is a unique community driven organisation that strives to 'do something practical' about protecting and repairing our environment. A diverse range of people take part in Landcare projects and activities – farmers, small landholders, schools and their students, professionals and visitors from across Australia and around the world.

#### **Maffra and District Landcare Network Inc.**

PO Box 727, Maffra VIC 3860

Ph. 1300 094 262

<http://westgippsland.landcarevic.net.au/mdln>

#### **East Gippsland Landcare Network Inc.**

PO Box 1498, Bairnsdale VIC 3875

Ph. 03 5152 0600

[www.egln.org.au](http://www.egln.org.au)

DISCLAIMER: This publication may be of assistance to you but the Maffra and District Landcare Network Inc. and the East Gippsland Landcare Network Inc. and their employees do not guarantee that the publication is without flaw of any kind or is wholly appropriate for your particular purposes and therefore disclaims any liability for any error, loss or other consequence that may arise from you solely relying on the information and instructions contained within this publication.

© Maffra and District Landcare Network Inc. 2009. This work is copyright. Apart from any use permitted under the Copyright Act 1968, no part may be reproduced by any process, nor can any other exclusive right be exercised, without the permission of the Maffra and District Landcare Network Inc.



CARING  
FOR  
OUR  
COUNTRY

# CONTENTS

<b>Introduction.....</b>	<b>1</b>
<b>Bird nest boxes .....</b>	<b>2</b>
- <i>Eastern Rosella</i> .....	2
- <i>Crimson Rosella</i> .....	4
- <i>Rainbow Lorikeet</i> .....	6
- <i>Kookaburra</i> .....	8
- <i>Owlet Nightjar</i> .....	10
- <i>Grey Shrike-thrush</i> .....	12
- <i>Treecreeper</i> .....	14
- <i>Pardalote</i> .....	16
- <i>Teal</i> .....	18
- <i>Pacific Black Duck</i> .....	20
- <i>Welcome Swallow</i> .....	22
<b>Mammal nest boxes .....</b>	<b>24</b>
- <i>Bat</i> .....	24
- <i>Common Ringtail Possum</i> .....	26
- <i>Sugar Glider</i> .....	28
<b>Construction .....</b>	<b>30</b>
<b>Installation .....</b>	<b>31</b>

<b>Typical nest box detailing .....</b>	<b>32</b>
<b>Installation diagram .....</b>	<b>34</b>
<b>Maintenance and monitoring .....</b>	<b>35</b>
<b>Notes .....</b>	<b>36</b>
<b>Nest box survey monitoring sheet .....</b>	<b>37</b>
<b>References .....</b>	<b>38</b>

# INTRODUCTION

The substantial clearing of natural vegetation and the removal of old growth trees containing hollows has resulted in the loss of habitat for many native birds and mammals.

Many native species depend on tree hollows for shelter, refuge and breeding.

Tree hollows can take more than 100 years to form. Unfortunately by this time the tree may be seen as unsafe, dead or a good source of firewood.

In urban areas, a lack of natural hollows forces some native birds and mammals to take up residence in peculiar places such as gutters, roof spaces and fuse boxes.

Many native species not only rely on hollows for nesting and breeding but require hollows for their day to day shelter, protection and survival.

Nest boxes or 'artificial hollows' can be used as a means of compensating for this loss of natural habitat, and protecting our precious native birds and mammals while natural hollows and habitat are established through Landcare type activities.

This booklet is designed to help with the correct construction, installation, maintenance and monitoring of nest boxes for 14 species of birds and mammals found in the Gippsland region.



Map highlighting the region of Gippsland within Victoria.



### ***The Eastern Rosella***

Eastern Rosellas commonly feed on grass seeds, eucalypt, wattle, shrubs, berries, blossom and small insects. When installing nest boxes it is important to consider the diet of the desired inhabitant. Planting suitable vegetation will encourage wildlife to the site of the nest box. It is also important to consider the characteristics of the bird when selecting a nesting site. Like most birds the Eastern Rosella is a shy bird which doesn't like to be disturbed. Thus, its nest box should ideally be placed at a good distance to avoid having them abandon their nest.

Like most bird species the female Eastern Rosella is distinctively less colourful than its male counterpart. Adult Eastern Rosellas have a crimson head and upper breast, white throat and cheeks with hints of bright green throughout (see left).

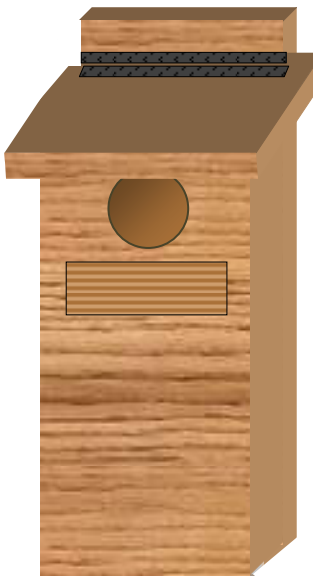

#### ***Nesting***

Number of eggs:  
4 -7 (white)

Incubation:  
35 days



#### ***Habitat***

Eastern Rosellas are commonly found in south-eastern Australia where they generally populate farmlands, woodlands, gardens and parklands. They are extremely common in the Gippsland region. The best time to install an Eastern Rosella nest box is between June and February.



Wattle



Eucalypt



Berries

# EASTERN ROSELLA NEST BOX

Bird Nest Box

Measurements are in millimetres (mm).  
Timber thickness 25mm.

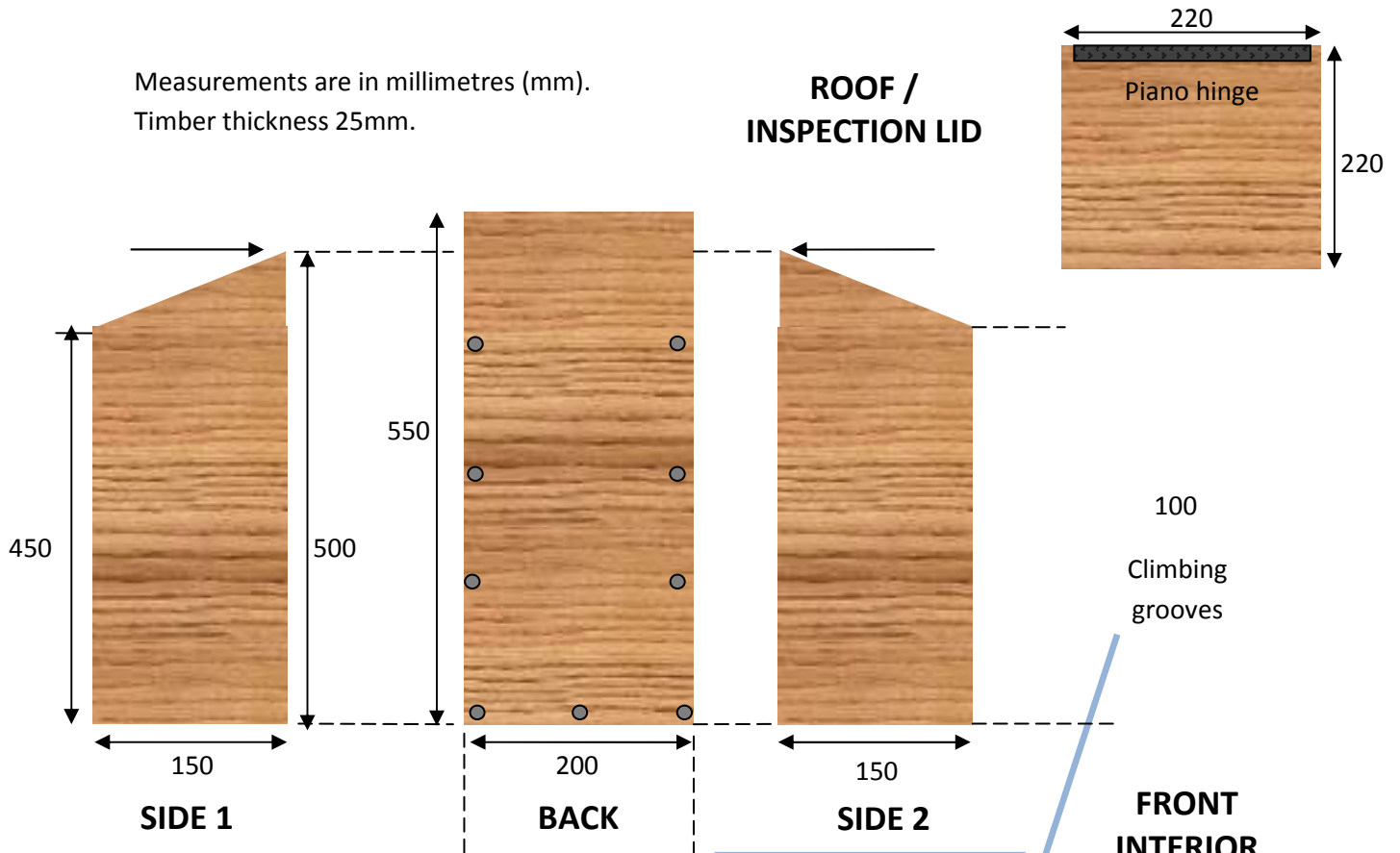

The Eastern Rosella, like most birds, will be attracted to boxes with ready made insulation such as wood shavings. However, this is optional as birds commonly build their own nests.

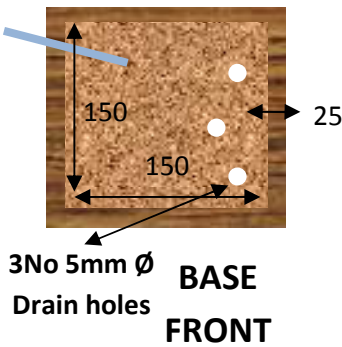

Saw cuts on the inside and outside of the box function as steps for the young. Avoid using wire mesh or other hard materials as ladders as the young can become tangled and subsequently injured.

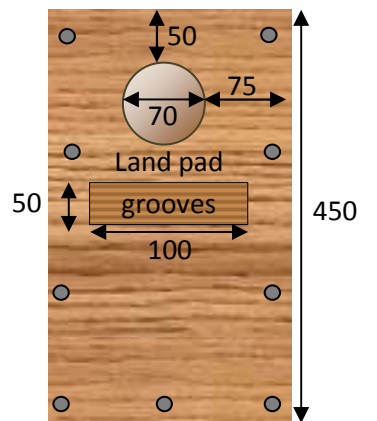

Because the Eastern Rosella is a shy bird the nest box should be placed 3 – 6 metres high, preferably on the trunk of a tree. The nest box should also be installed well away from heavy traffic areas such as front yards. It is essential that human activity surrounding the nest box is kept to a minimum because these parrots may desert their nests if they feel vulnerable or endangered.

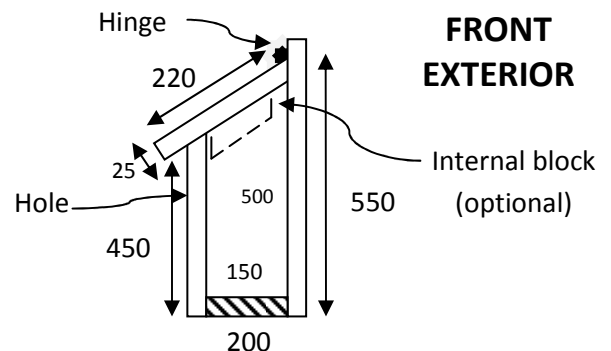



### ***The Crimson Rosella***

The Crimson Rosella is a well-recognised bird in the south-eastern region of Australia and parts of northern Queensland. It feeds on seeds, grasses, shrubs, berries, blossom and small insects. True to its name, the Crimson Rosella is predominantly crimson in colour, but it is the blue cheek patch which distinguishes it from other Rosella species. Other Crimson Rosellas include the Adelaide Rosella; it has a mottled orange appearance, and the Yellow Rosella which is completely blue and yellow.

#### ***Nesting***

Number of eggs:  
4 - 8 (white)

Incubation:  
20 days

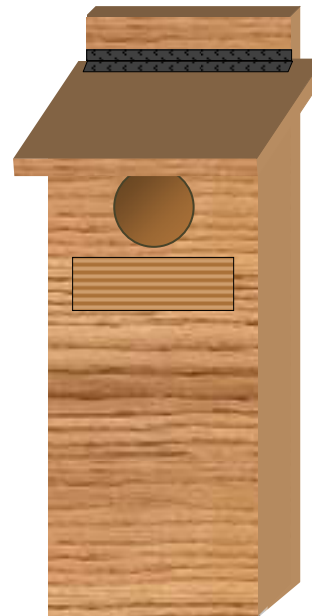

#### ***Habitat***

Crimson Rosellas like to inhabit tree tops in densely wooded areas, namely forests. However they are flexible birds, found scattered about in both rural and urban landscapes.



Blossom



Grass seeds



Berries



# CRIMSON ROSELLA NEST BOX

Bird Nest Box

The inspection lid is an important monitoring feature of all nest box designs. It allows humans to inspect the box for inhabitants, feral pests or other nuisances which may disturb the target species. Inspection lids must be waterproof.

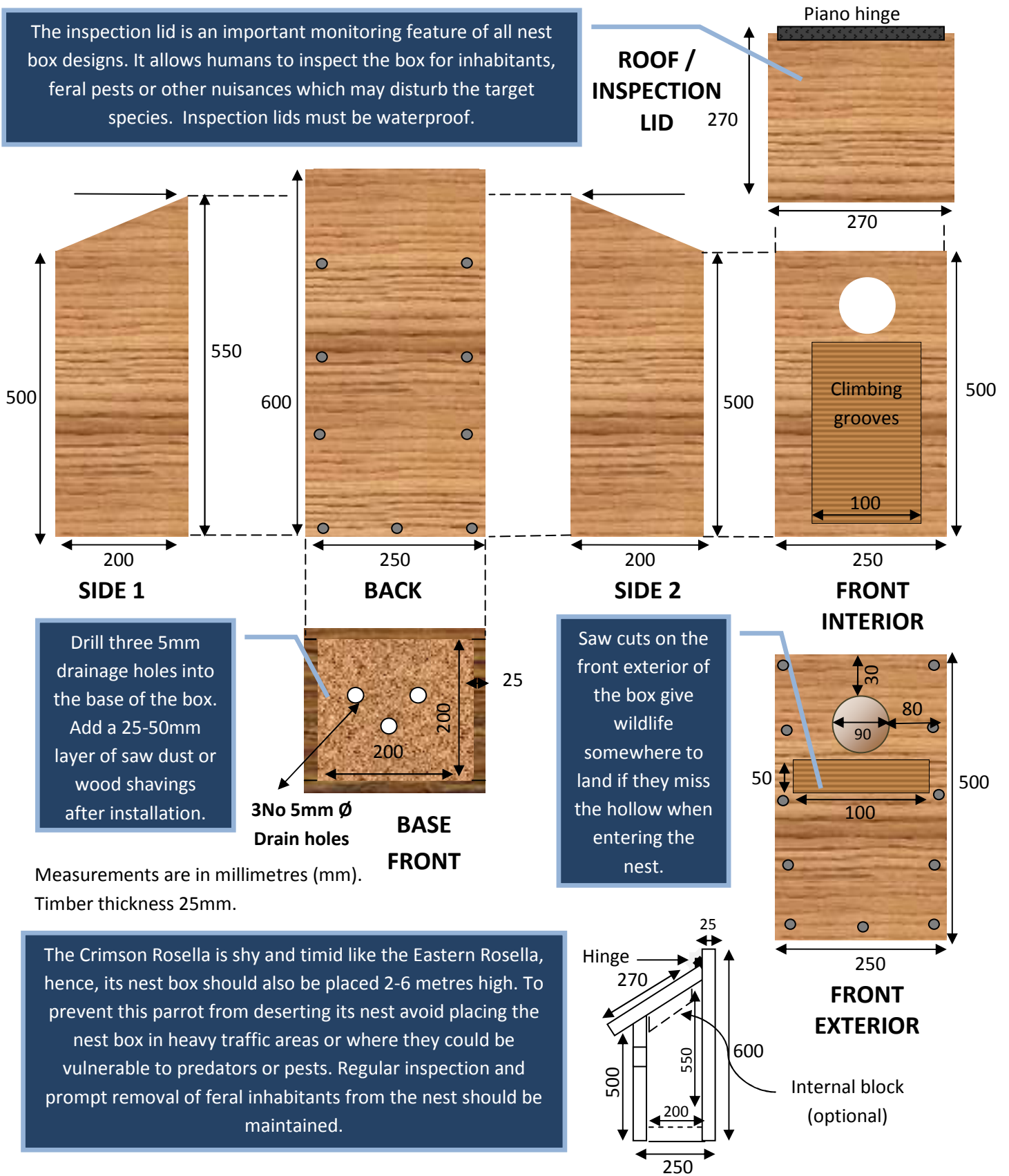

Drill three 5mm drainage holes into the base of the box. Add a 25-50mm layer of saw dust or wood shavings after installation.

Saw cuts on the front exterior of the box give wildlife somewhere to land if they miss the hollow when entering the nest.

Measurements are in millimetres (mm).  
Timber thickness 25mm.

The Crimson Rosella is shy and timid like the Eastern Rosella, hence, its nest box should also be placed 2-6 metres high. To prevent this parrot from deserting its nest avoid placing the nest box in heavy traffic areas or where they could be vulnerable to predators or pests. Regular inspection and prompt removal of feral inhabitants from the nest should be maintained.

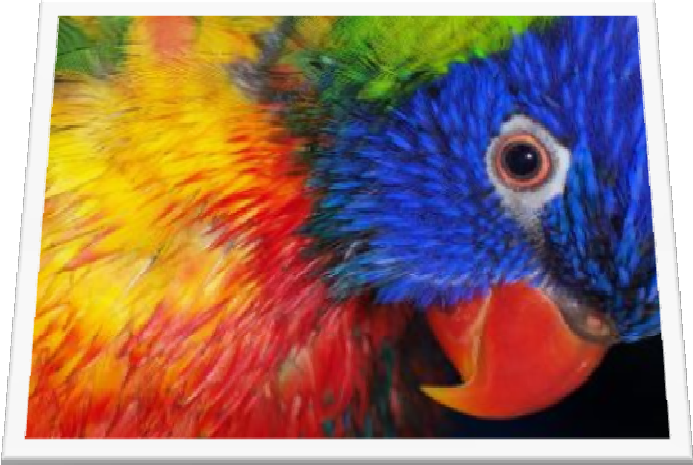

**Rainbow Lorikeet**

Rainbow Lorikeets are well-known for their distinctively bright plumage and human friendly nature. Their diet consists mainly of nectar, pollen and fruit such as grapes, apples and pears. Because of their diet they are often considered as pests to orchardists, therefore, fruit growers should refrain from installing Rainbow Lorikeet nest boxes near orchards. In spite of this bird's forthcoming nature, boxes should be placed in trees away from human activity.

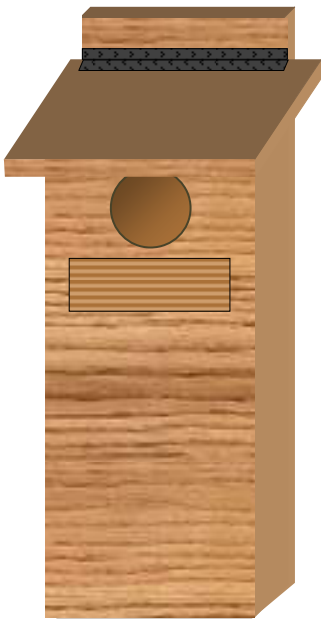

**Nesting**

Number of eggs:  
2-3 (white)

Incubation:  
23 days

**Habitat**

Rainbow Lorikeets are largely found in the eastern regions of Australia, as well as some parts of Western Australia. Due to its diet this bird will reside in any nectar producing area, particularly coastal scrubland, forests and suburban parks.



Crabapple



Grevillea



Pear

# RAINBOW LORIKEET NEST BOX

Bird Nest Box

Measurements are in millimetres (mm).  
Timber thickness 25mm.

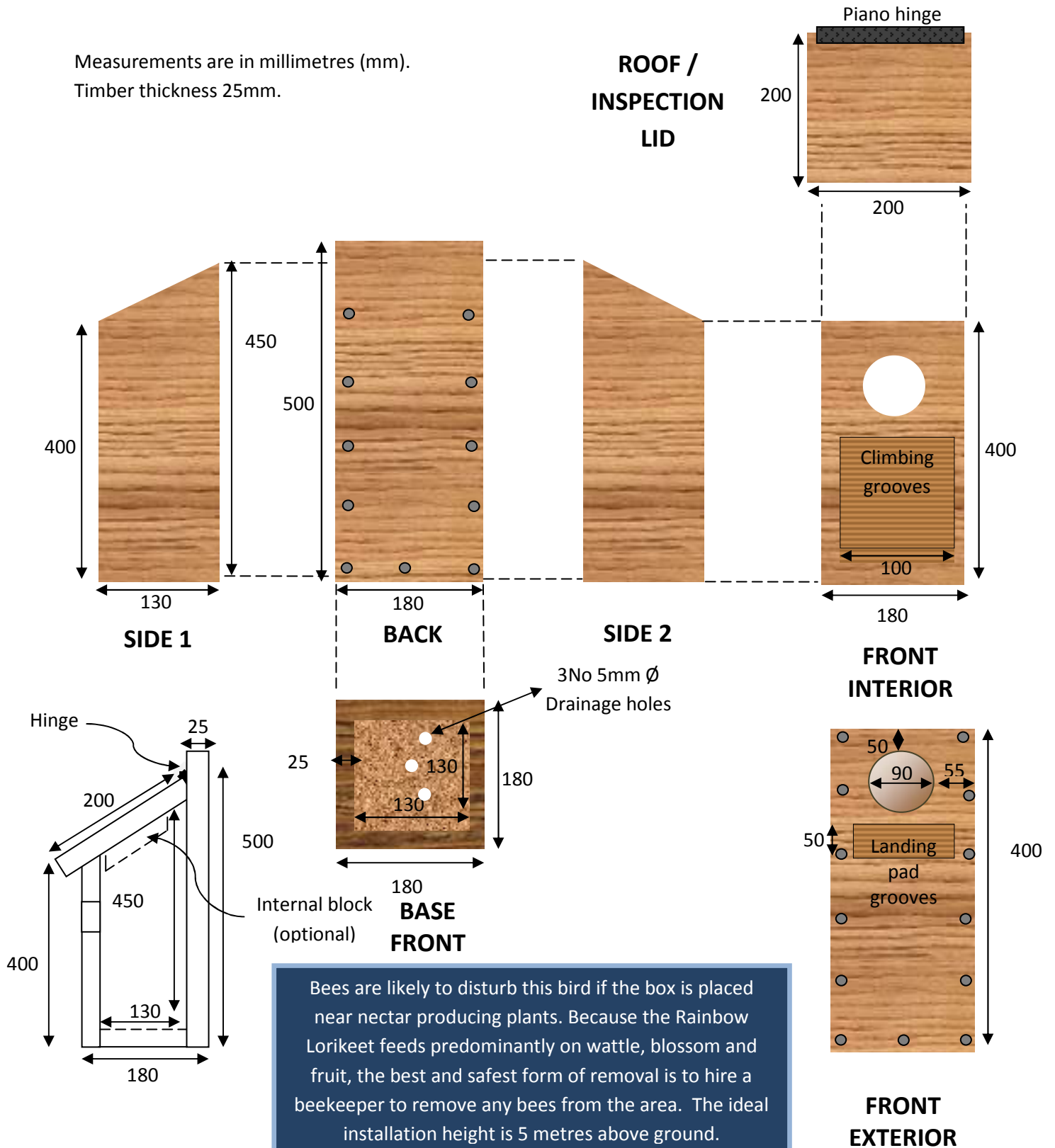



### **Laughing Kookaburra**

The Laughing Kookaburra is the largest of the kingfisher family. It can be found in open eucalypt forests and some suburban gardens of eastern and southern Australia. The Laughing Kookaburra was also introduced and established in Western Australia, Tasmania and New Zealand. Its diet consists of insects, small reptiles, rodents and nestlings, in which small prey is eaten whole and bigger prey is killed by being bashed against the ground or tree. The Laughing Kookaburra is renowned for its distinctive call which is suggestive of a laugh. It is predominantly brown and white with some blue flecks.

#### **Nesting**

Number of eggs:  
2-4 (white)

Incubation:  
35 days



#### **Habitat**

Kookaburras live in forests, open woodlands and rural and suburban areas; consequently they have become well accustomed to humans. Kookaburras live in family units where both sexes care for the young. Junior offspring are also known to help their parents with the young.



Swamp Rat



Brown-striped Frog



Copperhead Snake

Measurements are in millimetres (mm).  
Timber thickness 25mm.

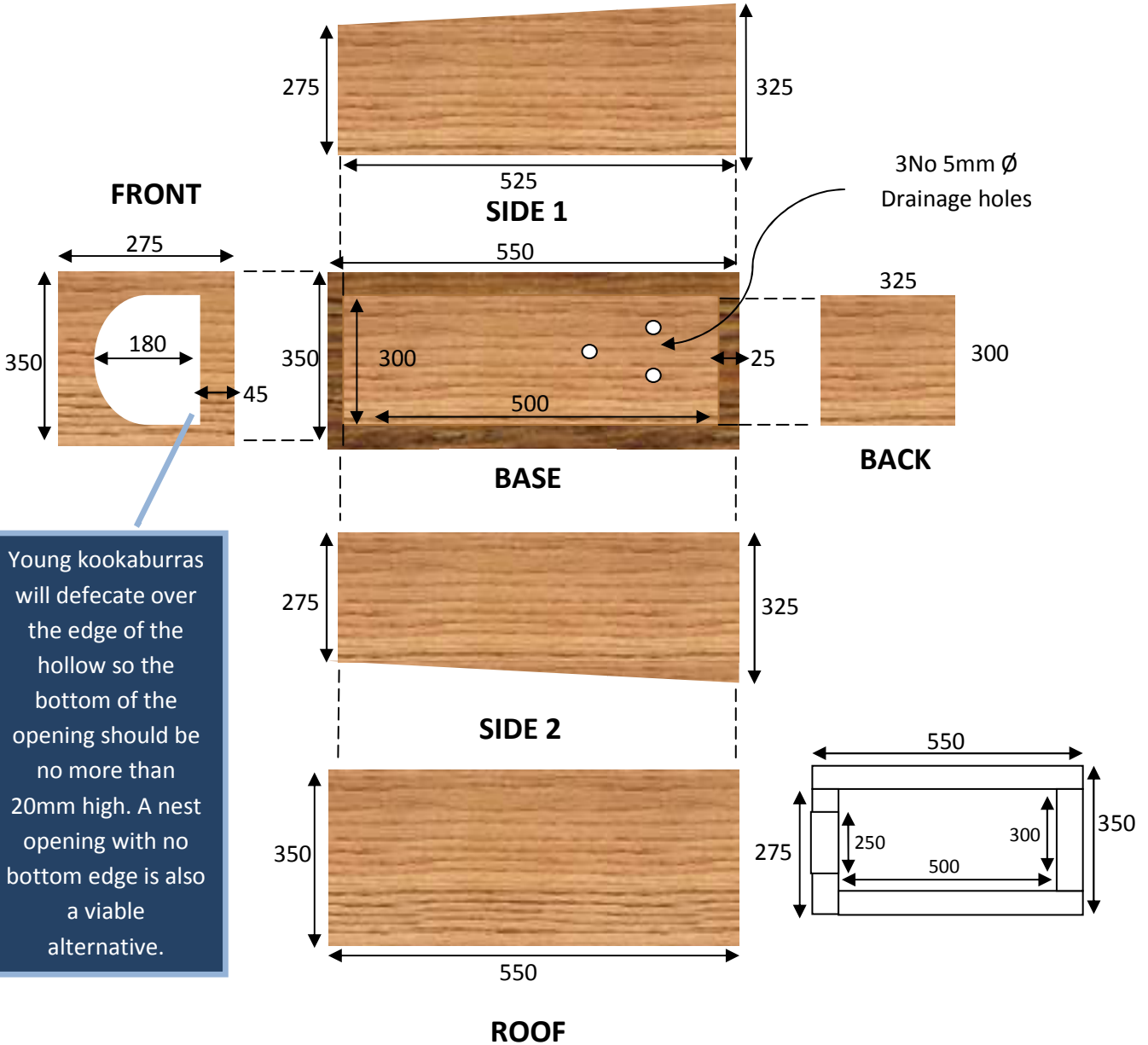

Young kookaburras will defecate over the edge of the hollow so the bottom of the opening should be no more than 20mm high. A nest opening with no bottom edge is also a viable alternative.

The nest box should be placed about 4-6 metres above ground with the box orientated so that the hollow is facing away from the sun and customary winds. Be careful not to exceed the installation height limit as regular maintenance and monitoring of the box can become a problem.



**Owlet Nightjar**

The Australian Owlet Nightjar is the smallest of the nocturnal birds found in Australia. They have a soft grey plumage that gives an almost perfect camouflage and large eyes that are non-reflective. Owlet Nightjars nest in hollows during the day and hunt at night, feeding on a variety of insects. These birds will readily take flying prey, or will pounce on prey either on the ground or in trees.

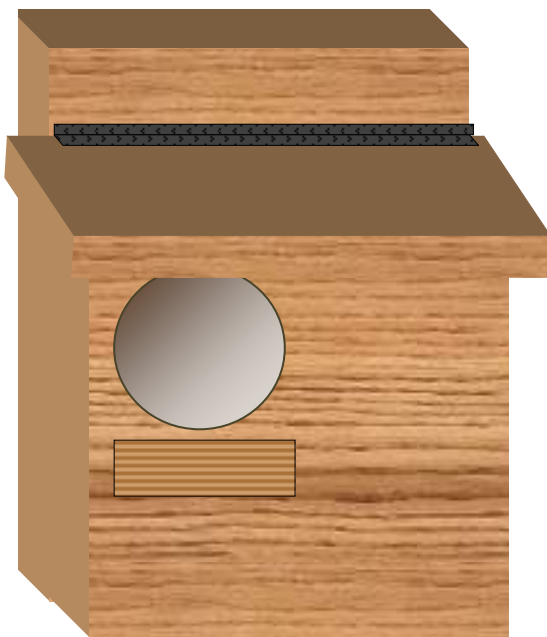

**Nesting**

Number of eggs:

2-5

Incubation:

28-30 days

**Habitat**

The Owlet Nightjar is common throughout Australia and its islands, as well as southern New Guinea. By day it roosts in tree hollows and occasionally in abandoned farmhouses, tunnels and earth banks. When installing nest boxes, make sure the tree is predator proof by placing a plastic sheet around the trunk of the tree. This will stop predators such as cats and foxes from climbing up the tree. Male and female companions share a territory but roost separately, however, when laying both companions incubate the eggs and care for the chicks.



Nursery-web Spider



Damselfly



Whirligig Beetle

Measurements are in millimetres (mm).  
Timber thickness 25mm.

Regular inspection for predators and other irritants, especially bees, spiders and ants should be maintained.

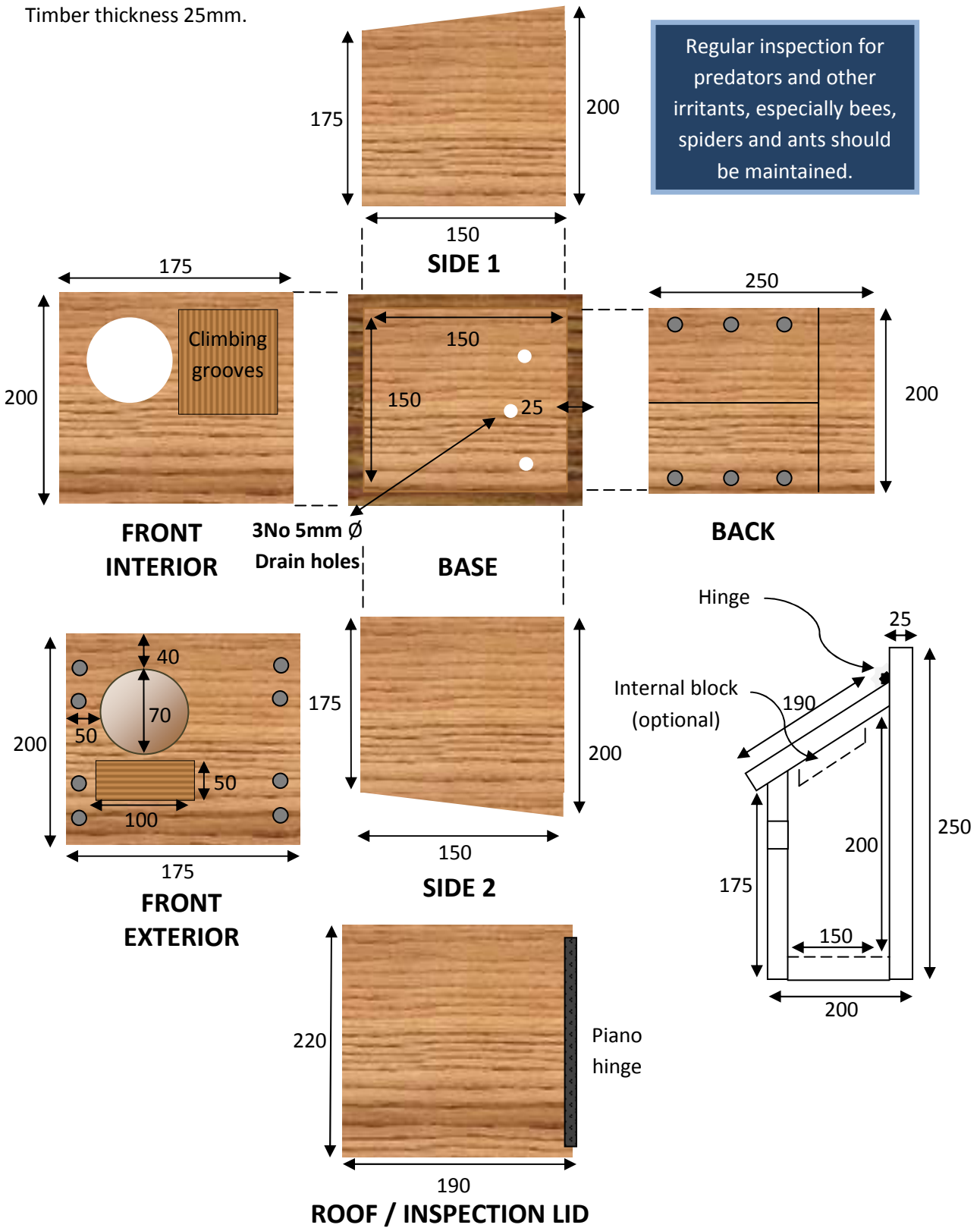

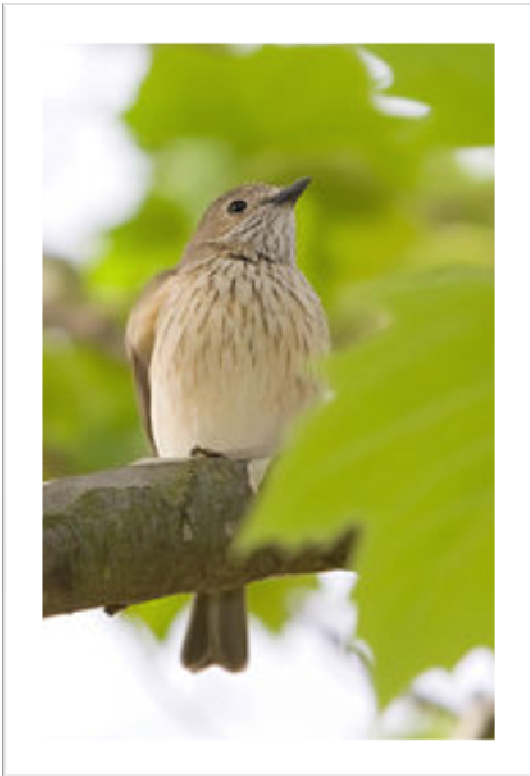

**Grey Shrike-thrush**

The Grey Shrike-thrush is often considered the most melodious of its species with a call that carries up to half a kilometre. Plumage of the Grey Shrike-thrush varies from region to region. It is grey in the east, brown in the north and grey with buff under-parts in western areas. The birds' diet consists of invertebrates, lizards, frogs, mice, eggs and nestlings. The Grey Shrike-thrush usually mates with a companion for life.

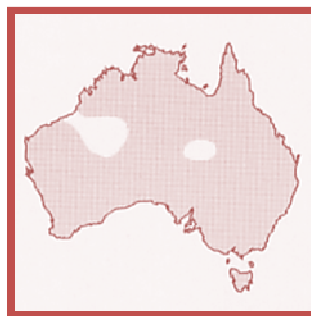

**Nesting**

Number of eggs:  
2-4 (creamy white)

Incubation:  
18 days

**Habitat**

The Grey Shrike-thrush is widespread throughout Australia and can be found in rainforests, eucalypt forests and woodlands. Western birds are generally shy and have not adapted well to the presence of humans whereas birds in the east are bolder, accepting handouts and building nests closer to human activity. The transition from hollow to box is largely trouble-free for these birds.



Frogs



Eggs



Skinks



Measurements are in millimetres (mm).  
Timber thickness 25mm.

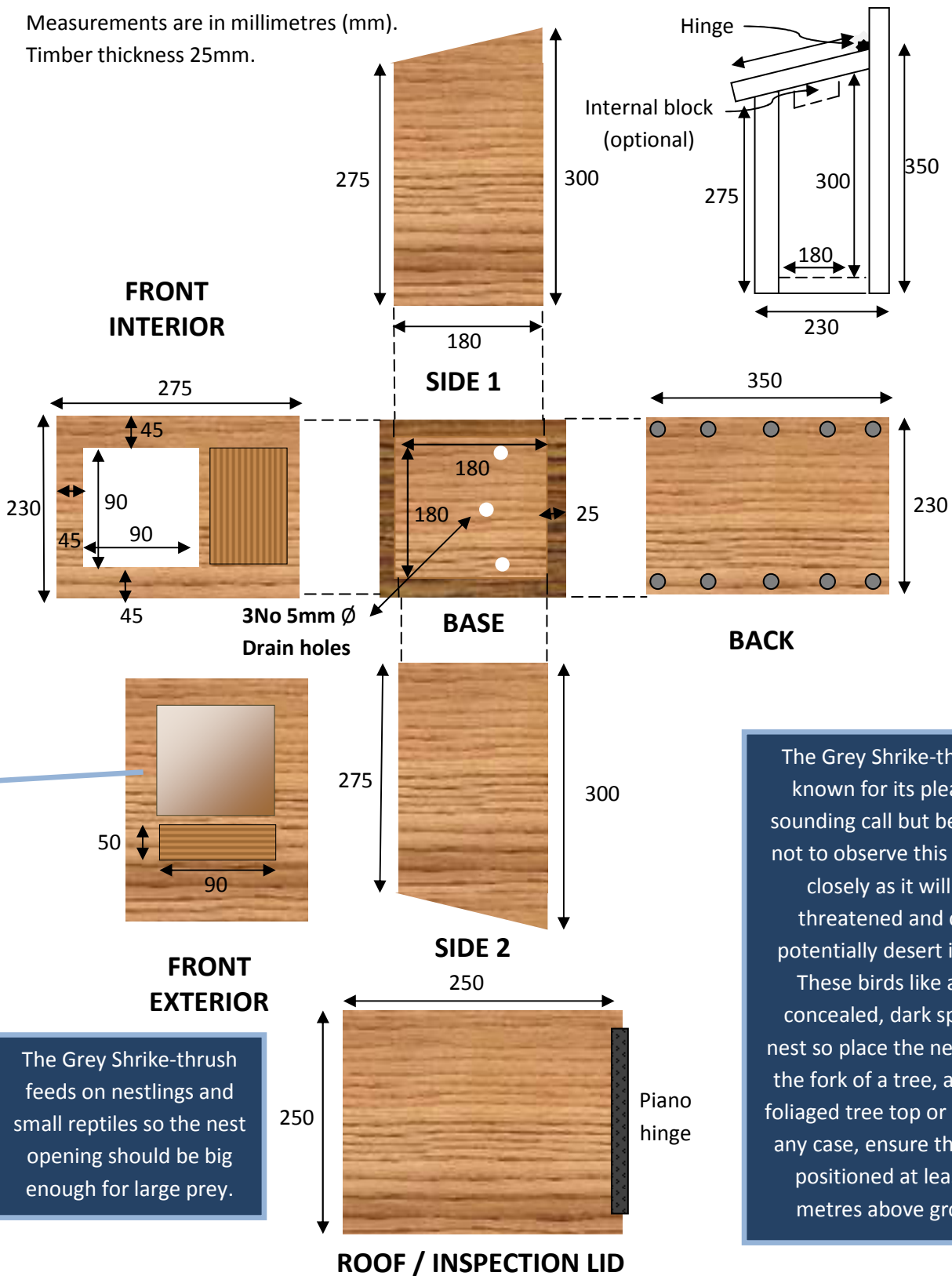

The Grey Shrike-thrush feeds on nestlings and small reptiles so the nest opening should be big enough for large prey.

The Grey Shrike-thrush is known for its pleasant-sounding call but be careful not to observe this bird too closely as it will feel threatened and could potentially desert its nest. These birds like a well concealed, dark space to nest so place the nest box in the fork of a tree, a heavily foliated tree top or shrub. In any case, ensure the box is positioned at least 2-5 metres above ground.



### **Treecreepers**

There are seven species of Treecreepers, six are found in Australia, the seventh is in New Guinea. They are generally brown with streaky patterns and have large feet and claws which help them climb vertically up tree trunks. Like woodpeckers they probe their bill under bark for insects and typically build nests in natural tree hollows.



#### **Nesting**

Number of eggs:  
2-3 (blotched)

Incubation:  
17 days

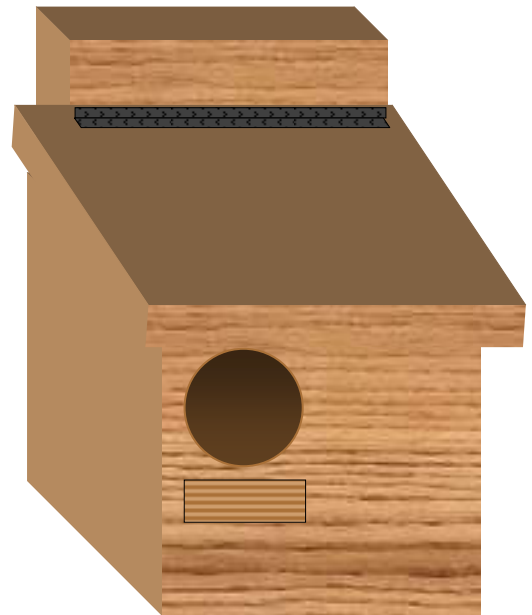

### **Habitat**

These birds are widely distributed across woodlands, rainforests and gardens in Australia and New Guinea.

### **Species in Gippsland**

- **White-throated Treecreeper,**  
*Cormobates leucophaea*
- **Red-browed Treecreeper,**  
*Climacteris erythroptera*
- **Brown Treecreeper,**  
*Climacteris picumnus*



Termites



Ants



Spiders

Measurements are in millimetres (mm).  
Timber thickness 25mm.

Treecreepers often feed the young of other Treecreepers, so don't be alarmed to find adult birds feeding the nestlings in your box. This particular nest box design is suitable for all three species of Treecreepers found within Gippsland. The recommended height for this box is 3-5 metres above ground.

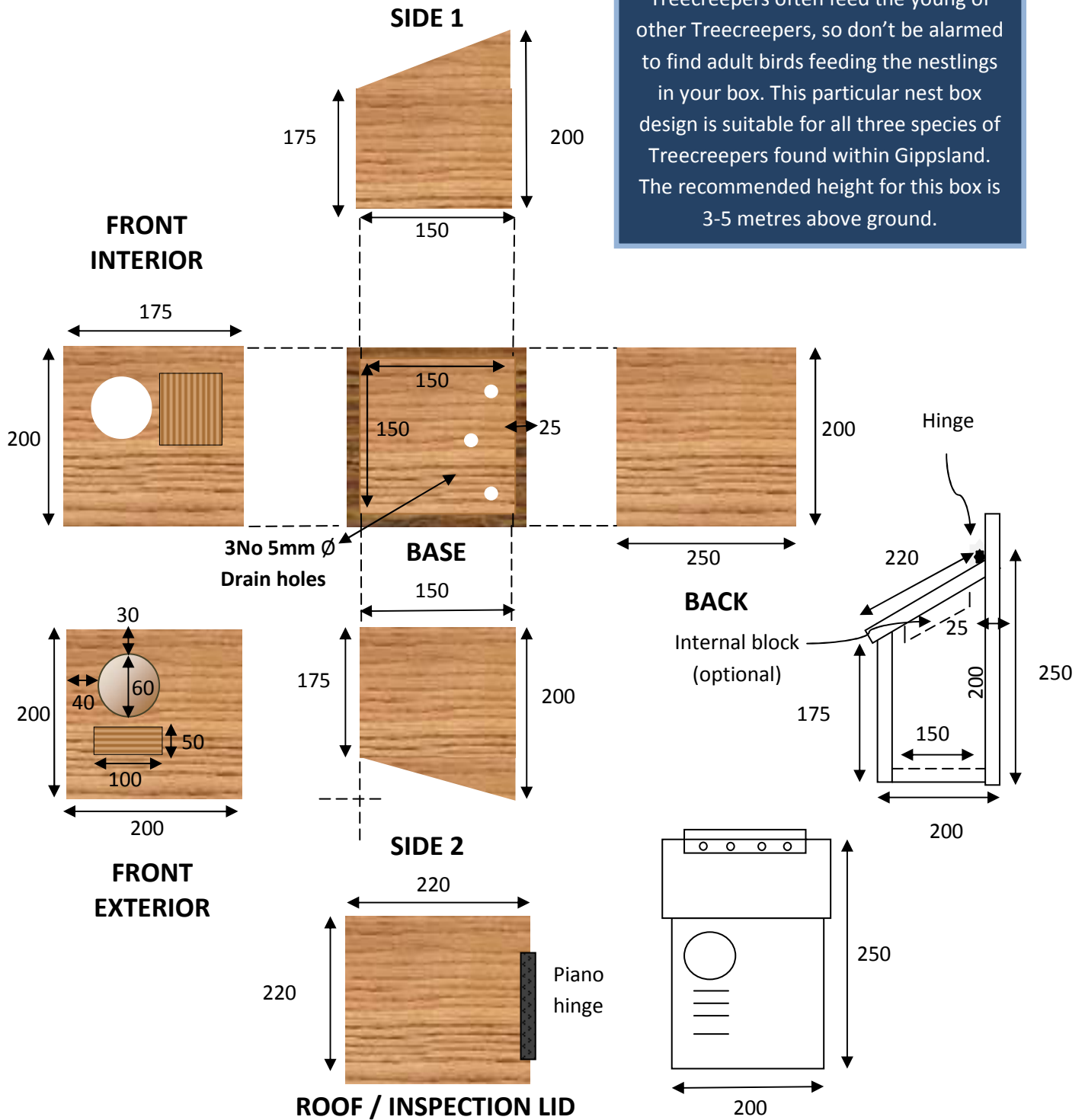



**Pardalote**

The four different species of Pardalotes are found throughout and only in Australia. They include the Spotted Pardalote, Striated Pardalote, Forty-spotted Pardalote and the Red-browed Pardalote. The four species comprise of black, brown or olive green feathers above and pale brown, grey and lemon yellow feathers below.

**Habitat**

Pardalotes inhabit trees and shrubs, favouring eucalypt forests and woodlands. They feed mainly in the canopies of tall eucalypts, capturing small insects and their larvae. All species build a domed or cup shaped nest either in a tree hollow or an earthen tunnel. Such nests are usually long and have a narrow entry. This should be mimicked in your nest box design.



Striated Pardalote distribution



Spotted Pardalote distribution

**Nesting**

Number of eggs:  
3-4 (white)  
Incubation:  
19 days

**Species in Gippsland**

- **Spotted Pardalote**, *Pardalotus punctatus*
- **Forty-spotted Pardalote**, *Pardalotus quadragintus*
- **Red-browed Pardalote**, *Pardalotus rubricatus*
- **Striated Pardalote**, *Pardalotus striatus*

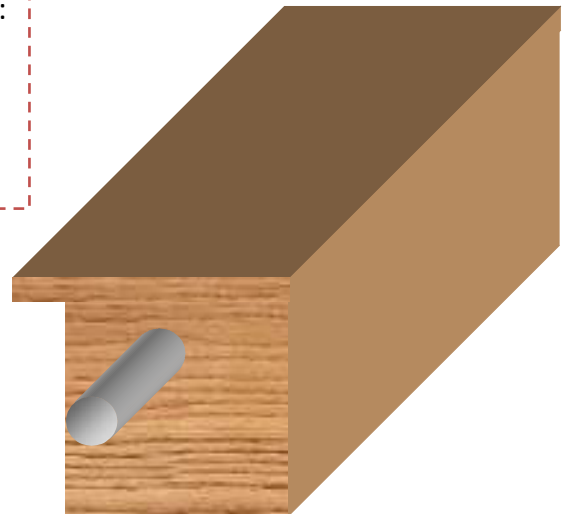

Grasshoppers



Eucalypt



Larvae

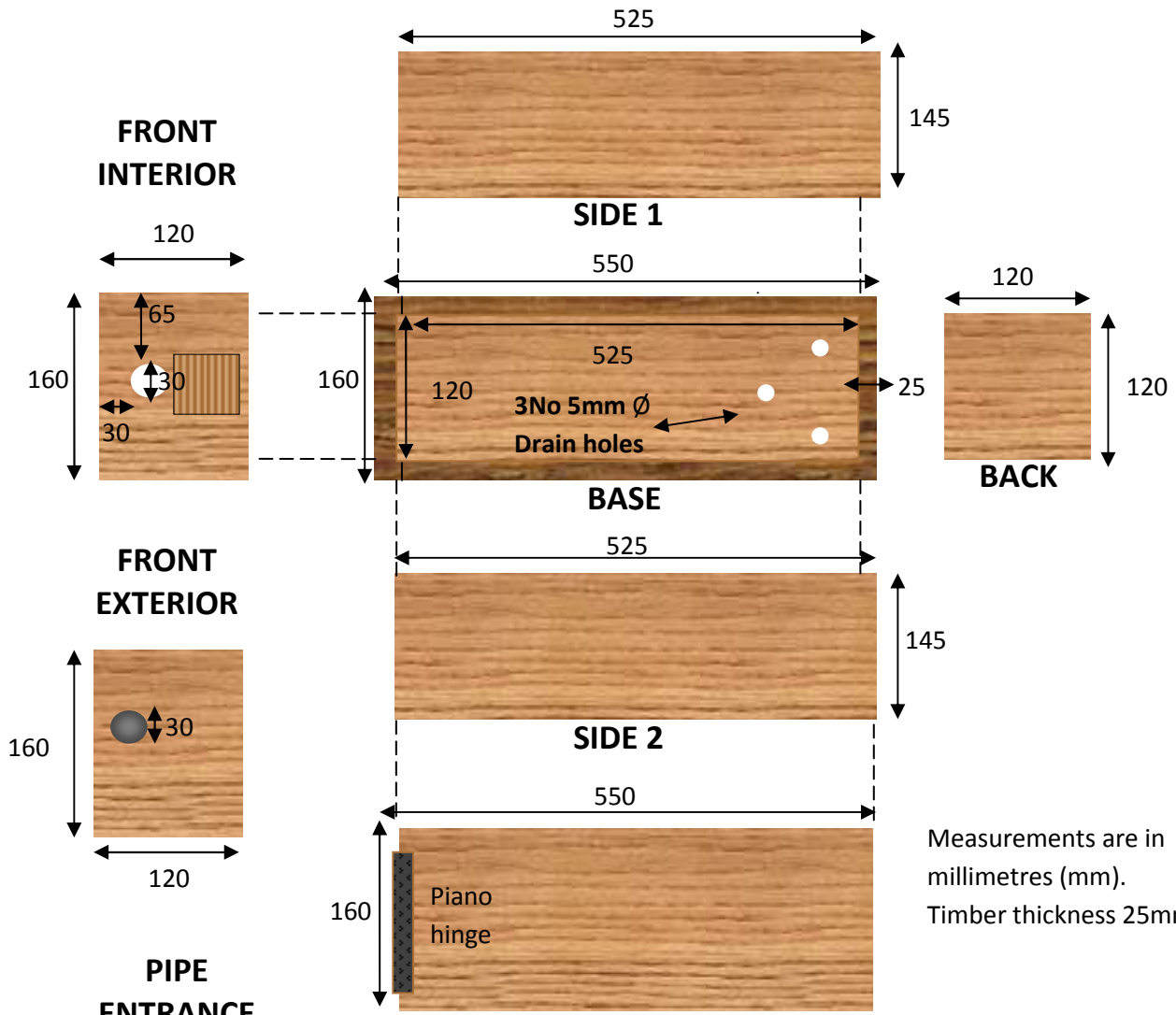

Measurements are in millimetres (mm).  
 Timber thickness 25mm.

Pardalotes regularly feed on insects in the foliage of trees so be sure to install the nest box in the canopy of a tree. The recommended height for the Pardalote nest box is 2 - 4 metres.

Pardalotes prefer a long, narrow entrance. A 100mm x 30mm internal diameter (I.D.) PVC pipe provides an ideal entrance.

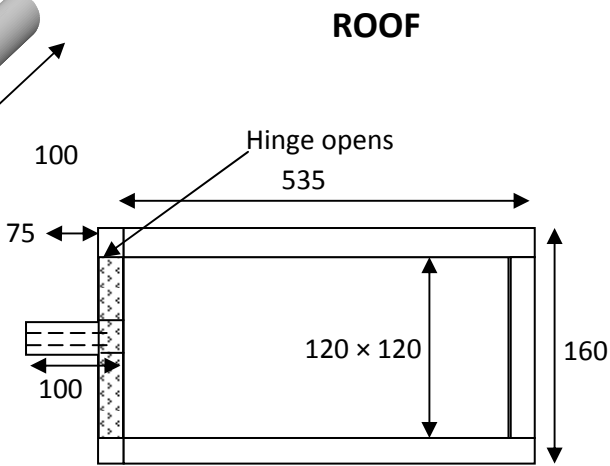



**Teal**

Teals are small ducks commonly found in wetlands all over Australia. They consist of two species; the Chestnut Teal and the Grey Teal. The male Chestnut Teal has a distinctive dark glossy green head and chestnut body whereas the female is brown all over. The Chestnut Teal feeds on seeds and insects, along with some vegetation and crustaceans in coastal regions. Grey Teals eat land plants, aquatic plants, seeds, crustaceans, and insects. Both males and females have a similar plumage of greyish brown feathers.

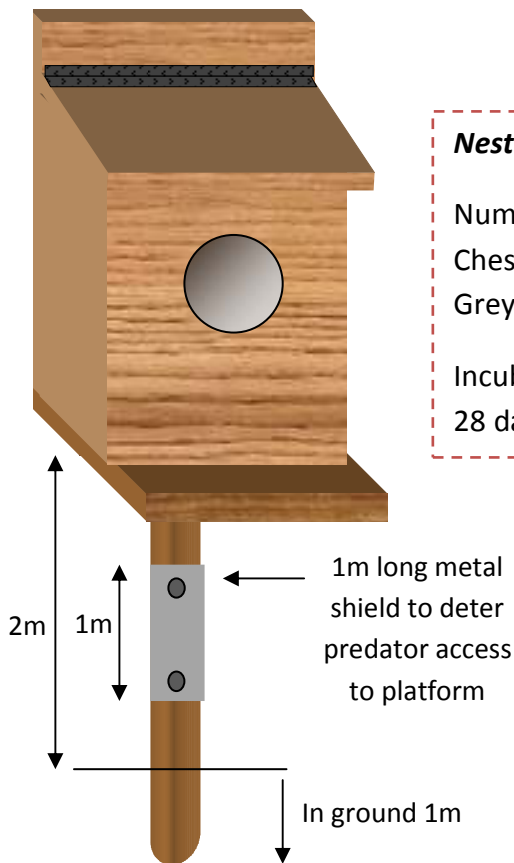

**Nesting**

Number of eggs:  
Chestnut Teal: 7-10  
Grey Teal: 6-9  
  
Incubation:  
28 days



Grey Teal distribution



Chestnut Teal distribution

**Species in Gippsland**

- Grey Teal, *Anas gracilis*
- Chestnut Teal, *Anas castanea*

**Habitat**

The Chestnut Teal is found in south-western and south-eastern Australia where it prefers coastal habitats. The Grey Teal on the other hand is distributed across Australia, favouring fresh water. Both teal species prefer to nest close to the water or on ground concealed by tall vegetation. This should be taken into consideration when placing its nest box.

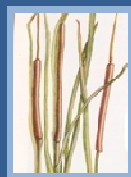

Cumbungi



Water Tiger



Common Water-milfoil

Measurements are in millimetres (mm).  
Timber thickness 25mm.

Cleaning the nest box after occupation is an important maintenance procedure for this particular box.

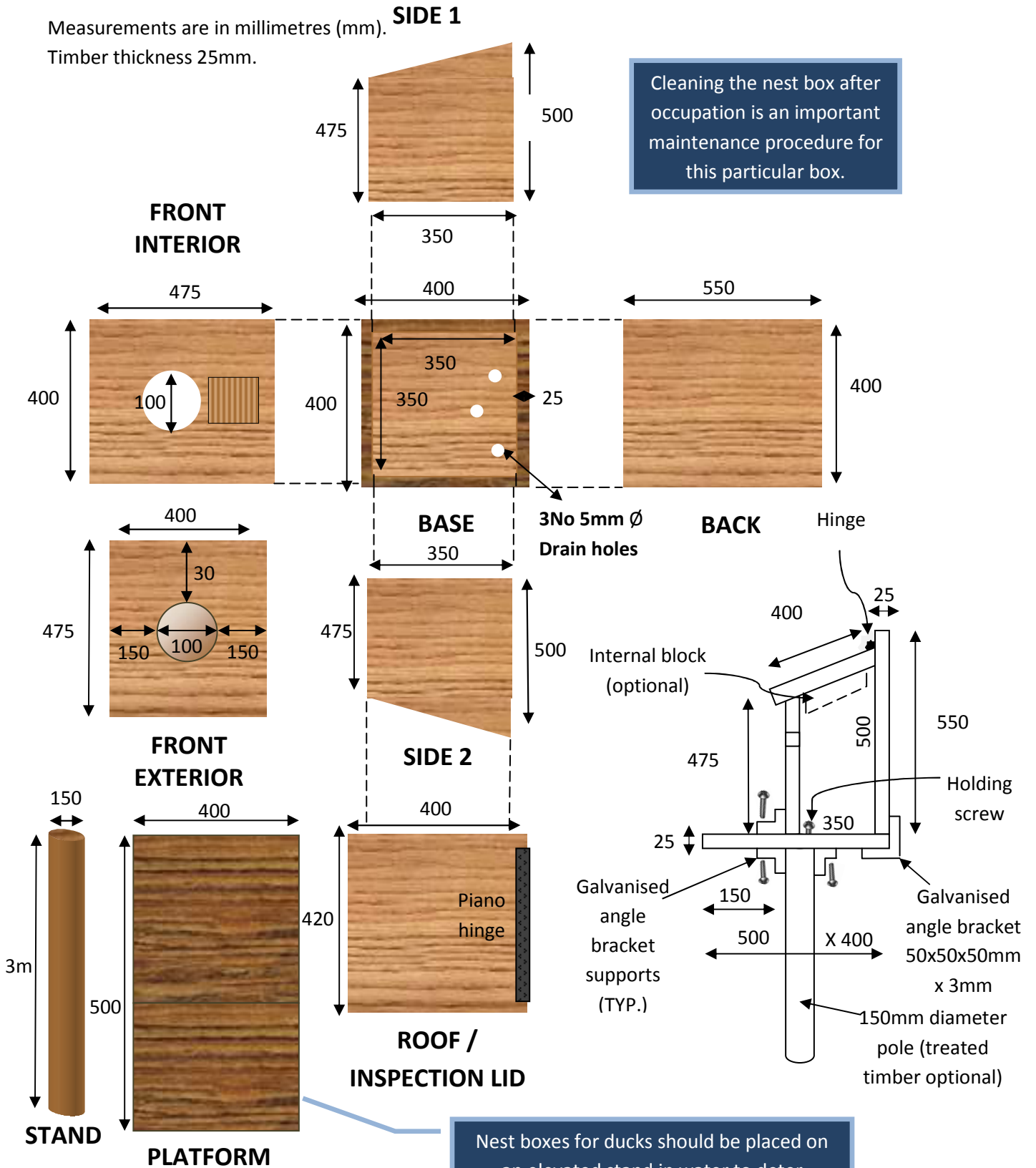

Nest boxes for ducks should be placed on an elevated stand in water to deter predators such as foxes.

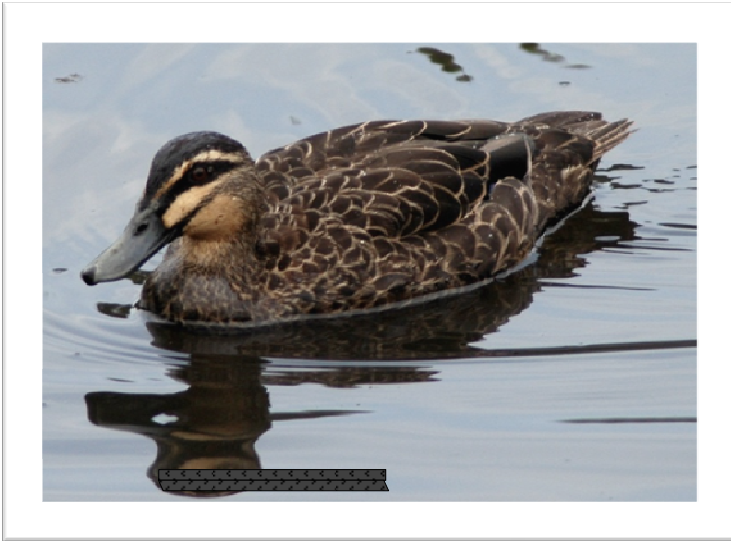

**Pacific Black Duck**

The Pacific Black Duck is native to Australia. Both sexes have distinctive black stripes on their head a similar plumage of brown feathers. This duck will feed on land and aquatic plants as well as insects.

**Habitat**

The Pacific Black Duck can be found in almost any watery habitat such as lakes, ponds, swamps and lagoons. It also occupies rural and suburban parks. Nests are often made in tree hollows or on ground among vegetation. Nest boxes should be placed near water in a tree or on a stand to deter cats and foxes.

**Nesting**

Number of eggs:  
6 – 11 (white)

Incubation:  
26-30 days

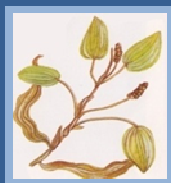
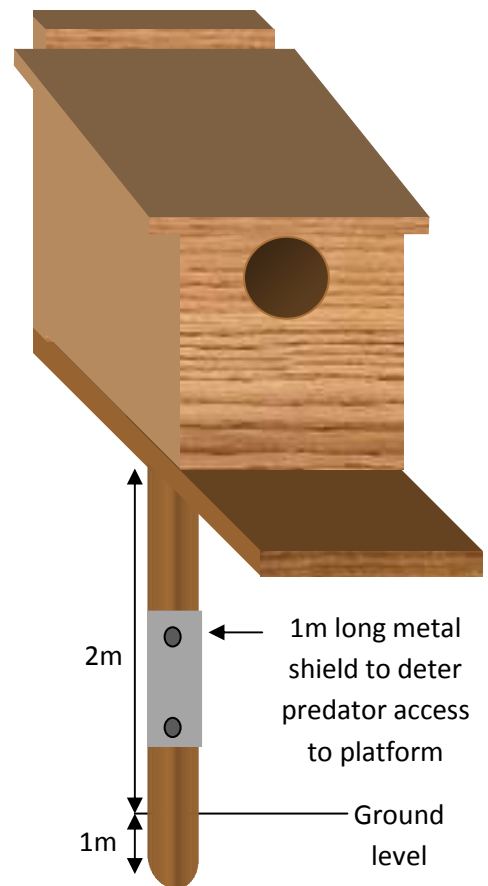

Floating Pondweed



River Flea

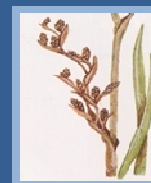

Common Sword-sedge



PACIFIC BLACK DUCK NEST BOX

Bird Nest Box

Measurements are in millimetres (mm).  
Timber thickness 25mm.

The Pacific Black Duck likes straw and other insulation in the base of its box.

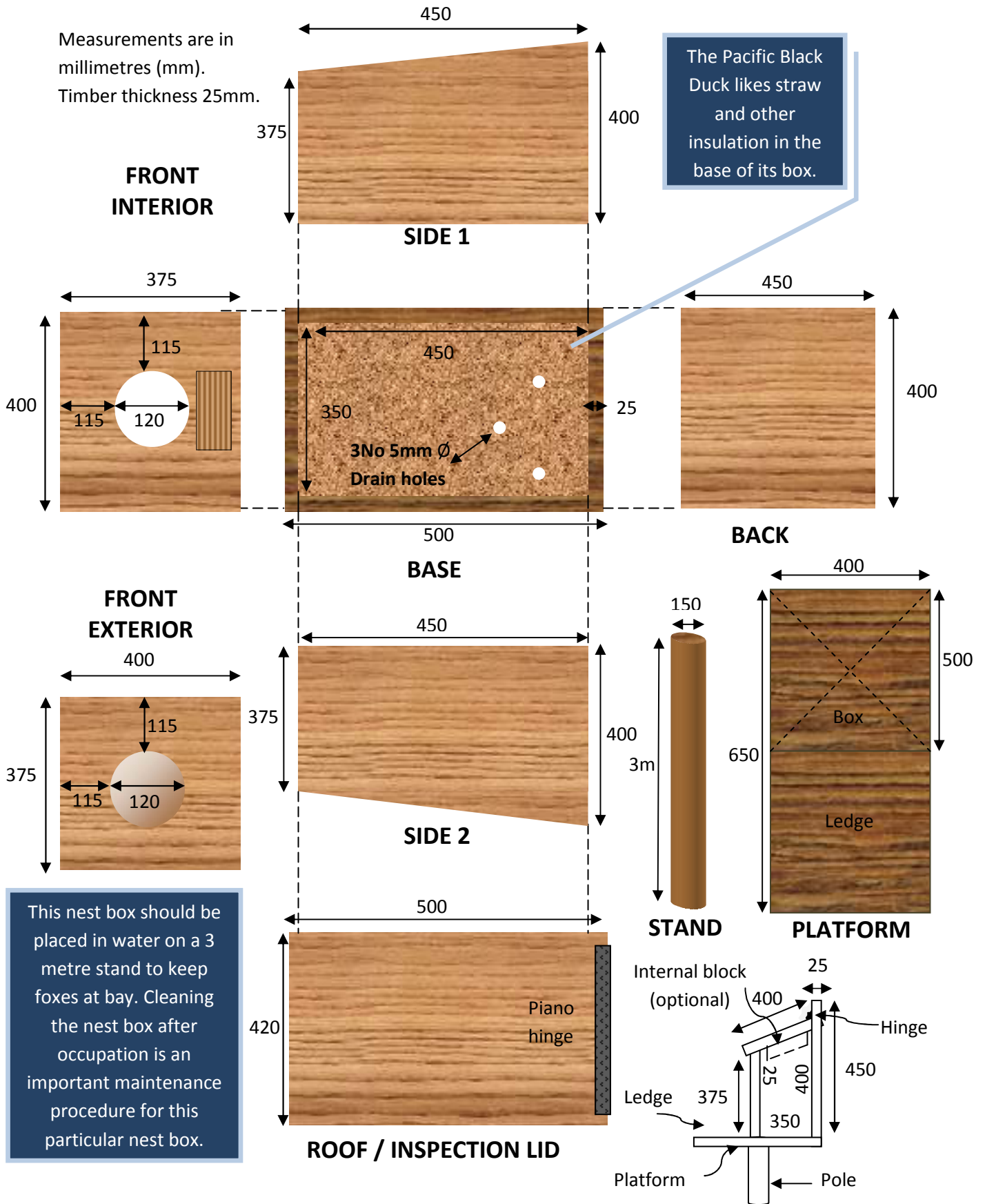

This nest box should be placed in water on a 3 metre stand to keep foxes at bay. Cleaning the nest box after occupation is an important maintenance procedure for this particular nest box.



**Welcome Swallow**

The Welcome Swallow is one of the most common species of swallows found in Australia. It has glossy blue-black wings, a white body and a red rustic forehead, throat and upper breast. Welcome Swallows feed on a variety of insects by catching their prey in flight. Like most birds they will migrate in response to the availability of food.



**Nesting**

Number of eggs:  
3-5 (speckled)  
Incubation:  
21 days

**Habitat**

The Welcome Swallow can be found throughout Australia but is less common in the northern regions of Western Australia and the Northern Territory. It inhabits all but dense forests and arid areas. Welcome Swallows often nest in cup-shaped mud formations which are lined with feathers, fur and grass. The nest is often attached to vertical structures such as walls and cliffs, as well as under eaves and verandas. Nest boxes should always be placed in areas similar to their natural habitat.

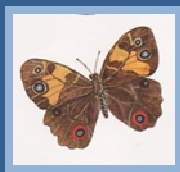
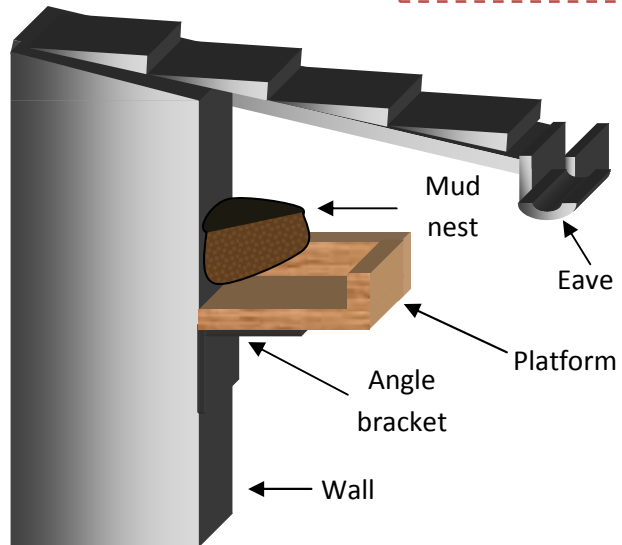

Sword-grass Brown  
Butterfly



Mayfly



True Midge

Measurements are in millimetres (mm).  
Timber thickness 25mm.

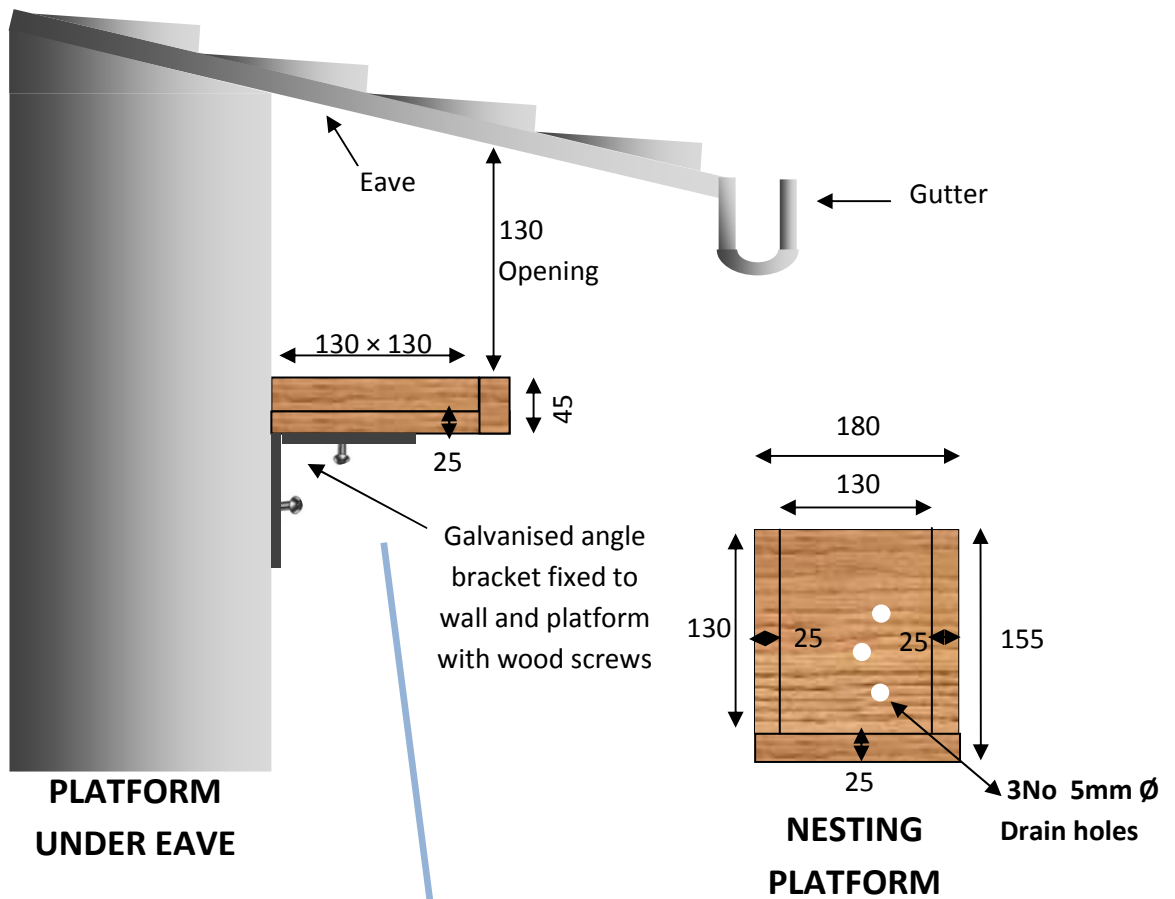

Due to its open design, this type of platform can be easily monitored for the presence of feral birds or pests.

The nesting platform should be installed directly under eaves or verandahs for shelter and protection. If the birds are nesting successfully without the platform be quick to remove it to prevent feral birds from using it.



**Bats**

There are 90 known species of bats in Australia, 23 are found in Victoria and 16 within Gippsland. There are two major categories of bats, Megachiroptera and Microchiroptera. The Megachiroptera bats – also known as the megabats (big bats) – are your fruit bats, blossom bats and flying foxes. These bats use their sharp eyesight for finding fruits and flowers which make up their diet. These bats do not roost in tree hollows but instead hang from trees. The Microchiroptera bats – also known as microbats (little bats) – feed on insects. They navigate by their sense of hearing and use echolocation which is a sonar pulse detected on objects in their environment. Unlike the megabats, these small bats will roost in tree hollows, domestic spaces, caves and available nest boxes.

**Habitat**

Bat species are widely distributed across Australia including Lord Howe and Christmas Island. They often inhabit forested areas and caves. Bats are very important to our ecology as they help control insect populations and assist in pollination.



**Species in Gippsland**

- **Chocolate Wattled Bat**, *Chalinolobus gouldii*
- **Eastern Freetail Bat**, *Mormopterus sp.*
- **Gould’s Long-eared Bat**, *Nyctophilus gouldii*
- **Lesser Long-eared Bat**, *Nyctophilus geoffroyi*
- **Large Forest Bat**, *Vespadelus darlingtoni*
- **Southern Forest Bat**, *Vespadelus regulus*
- **Little Forest Bat**, *Vespadelus vulturnus*
- **Gould’s Wattled Bat**, *Chalinolobus gouldii*
- **Eastern False Pipistrelle**, *Falsistrellus tasmaniensis*
- **Southern Myotis**, *Myotis macropus*
- **Eastern Broad-nosed Bat**, *Scotorepens orion*
- **White-striped Freetail Bat**, *Tadarida australis*
- **Yellow-bellied Sheathtail Bat**, *Saccolaimus flaviventris*



Blossom



Moths



Crabapple

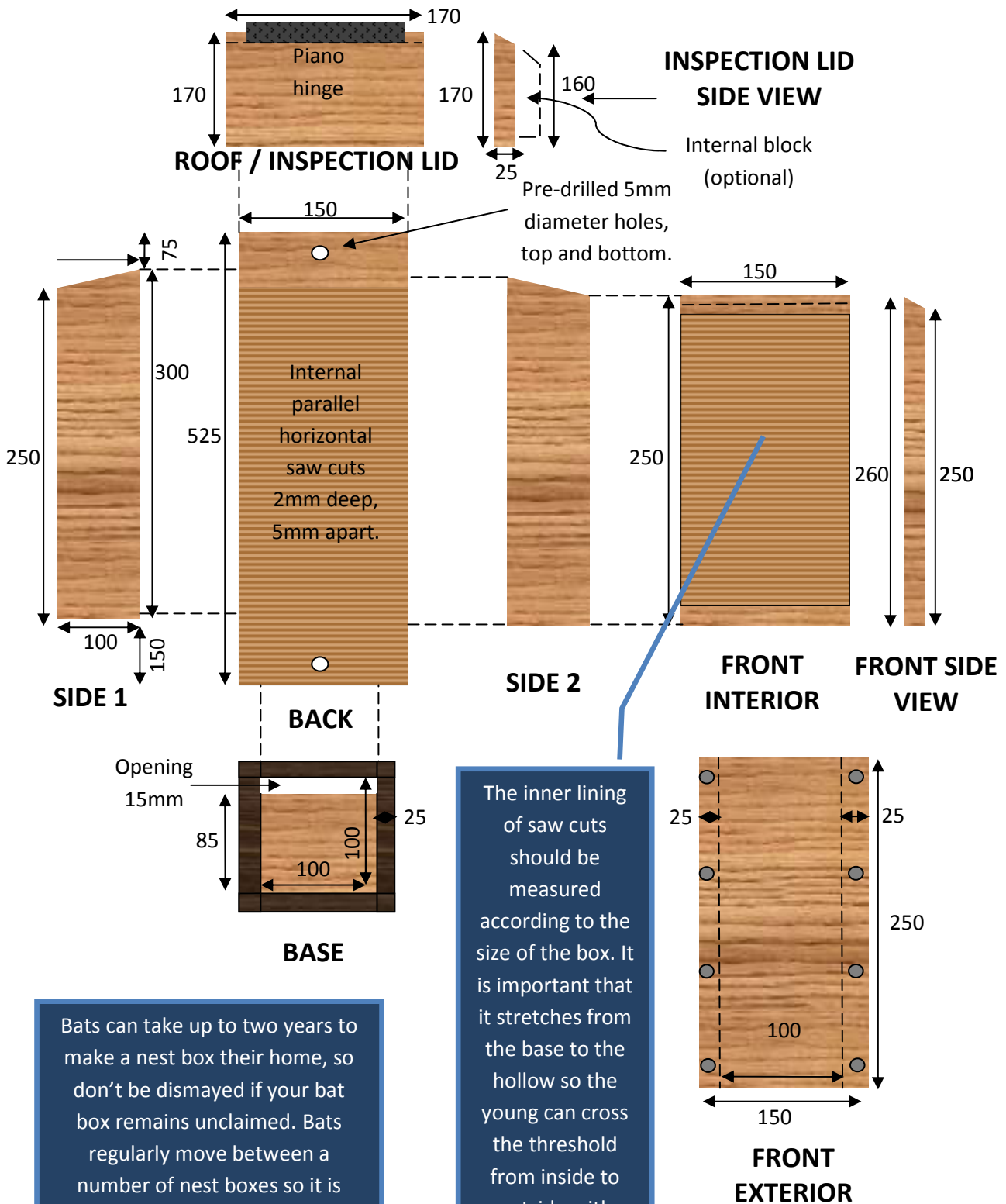

The inner lining of saw cuts should be measured according to the size of the box. It is important that it stretches from the base to the hollow so the young can cross the threshold from inside to outside with relative ease.

Bats can take up to two years to make a nest box their home, so don't be dismayed if your bat box remains unclaimed. Bats regularly move between a number of nest boxes so it is important to have a large number of roost sites in the one area, eg. 10 -15. The ideal installation height for this nest box is 2-4 metres.

Measurements are in millimetres (mm).  
Timber thickness 25mm.

***Common Ringtail Possum***

The Common Ringtail Possum is grey with white patches on the belly. The possum's tail has an orange-brown tinge and white tip that is used to climb and jump between branches, fences and power lines. This possum will feed on seeds, nectar, fruit, flowers and young vegetable seedlings. It is important to take this into account when installing a Common Ringtail Possum nest box.



***Habitat***

The Common Ringtail Possum is widely distributed across Victoria and the east coast of Australia. They can be found in eucalypt forests, woodlands, coastal regions, rainforests and suburban gardens.

These possums build nests commonly known as a 'drey.' They are made from grass and shredded bark and built in tree hollows or tree forks. The Common Ringtail Possum can often be found utilising roof tops and other domestic spaces as nests. Its nest box should provide a hollow big enough to get in and out of with relative ease.



Pears



Flowers



Crabapples

# COMMON RINGTAIL POSSUM NEST BOX

Mammal Nest Box

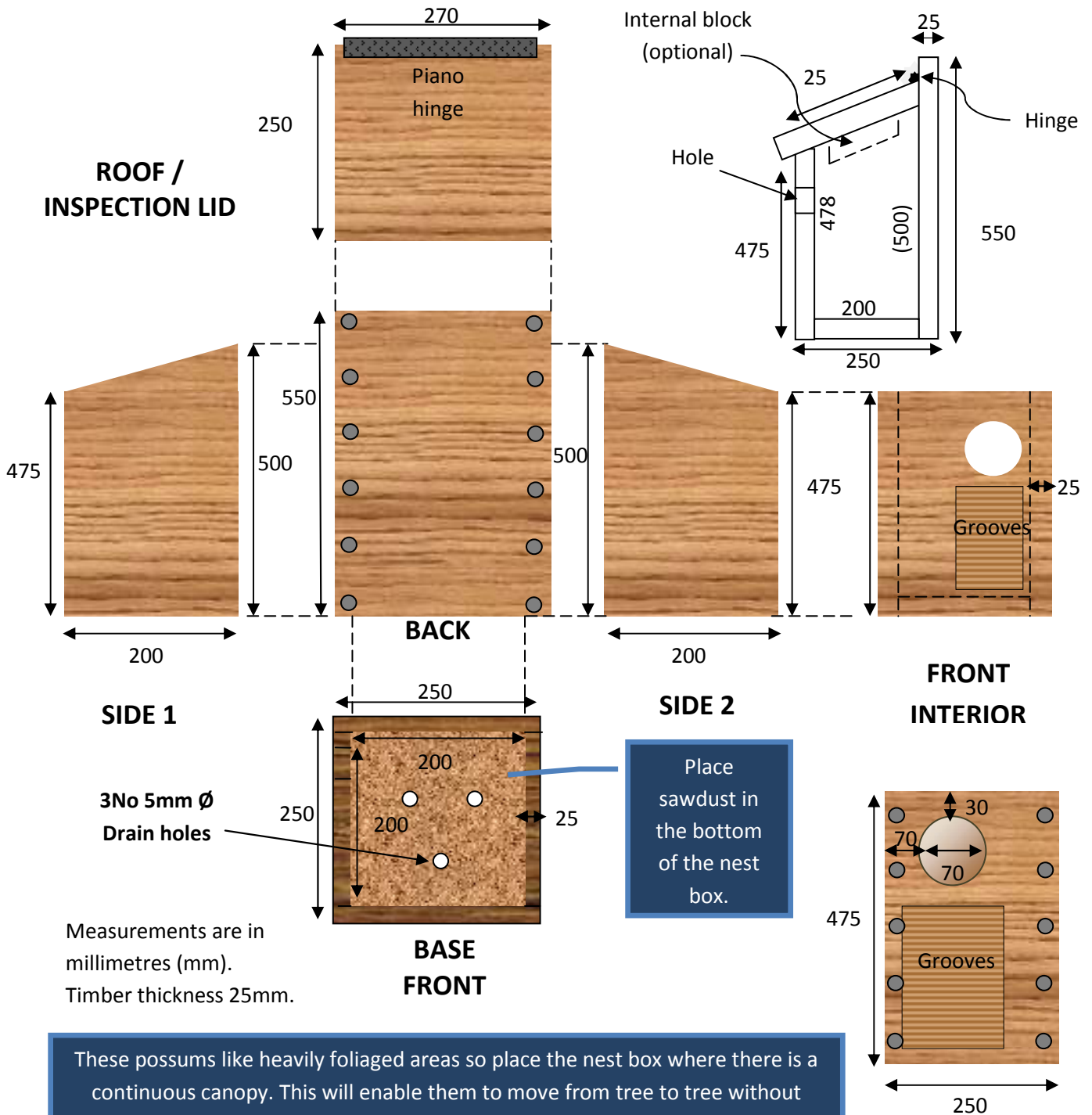

Measurements are in millimetres (mm).  
Timber thickness 25mm.

These possums like heavily foliated areas so place the nest box where there is a continuous canopy. This will enable them to move from tree to tree without having to walk on the ground where they are vulnerable to cats, dogs and foxes. You can also tie ropes to nearby trees as a means to keep predators at bay. Don't be alarmed to find possums nesting in other nest boxes; they will inhabit almost any box provided the hollow is big enough. If this occurs be sure to check the box for evidence of previous inhabitants as they may return to their nest. This nest box should be placed 3 metres above ground.



### ***Sugar Glider***

The Sugar Glider has a soft grey plumage and will grow up to 20 cm long. It launches itself with its hind legs and can 'fly' for at least 50 metres between trees. It also uses its long bushy tail for stability and steering when flying. Sugar Glider's diet, consisting of acacia gum, insects, spiders, nectar, honeydew, lerp, fruit and pollen, depends greatly upon habitat and season. The Sugar Glider commonly gives birth to twins which remain in the pouch for just over two months. Male and female offspring are often evicted from their territory before they are twelve months old, leaving them vulnerable to predators.

### ***Habitat***

The Sugar Glider is widely distributed in the north-eastern coastal areas of Australia as well as Tasmania and New Guinea. The Sugar Glider inhabits rainforests, wet eucalypt forests, woodlands and suburban backyards. They prefer nests made of leaves in tree hollows where they live communally in groups. The Sugar Glider is known to become very territorial. It will defend its area aggressively, therefore, be careful not to disturb this mammal when nesting.

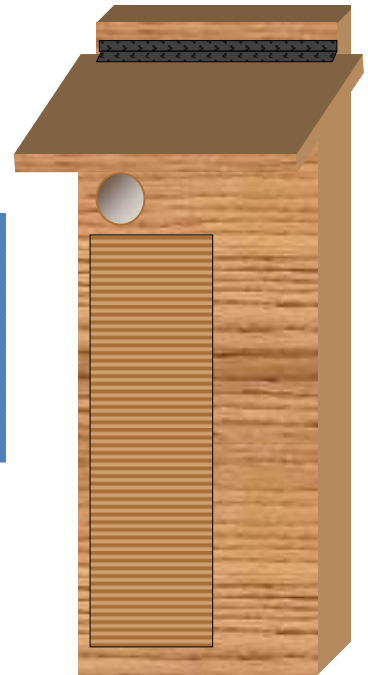

Honeydew



Spiders



Pollen



# SUGAR GLIDER NEST BOX

Mammal  
Nest Box

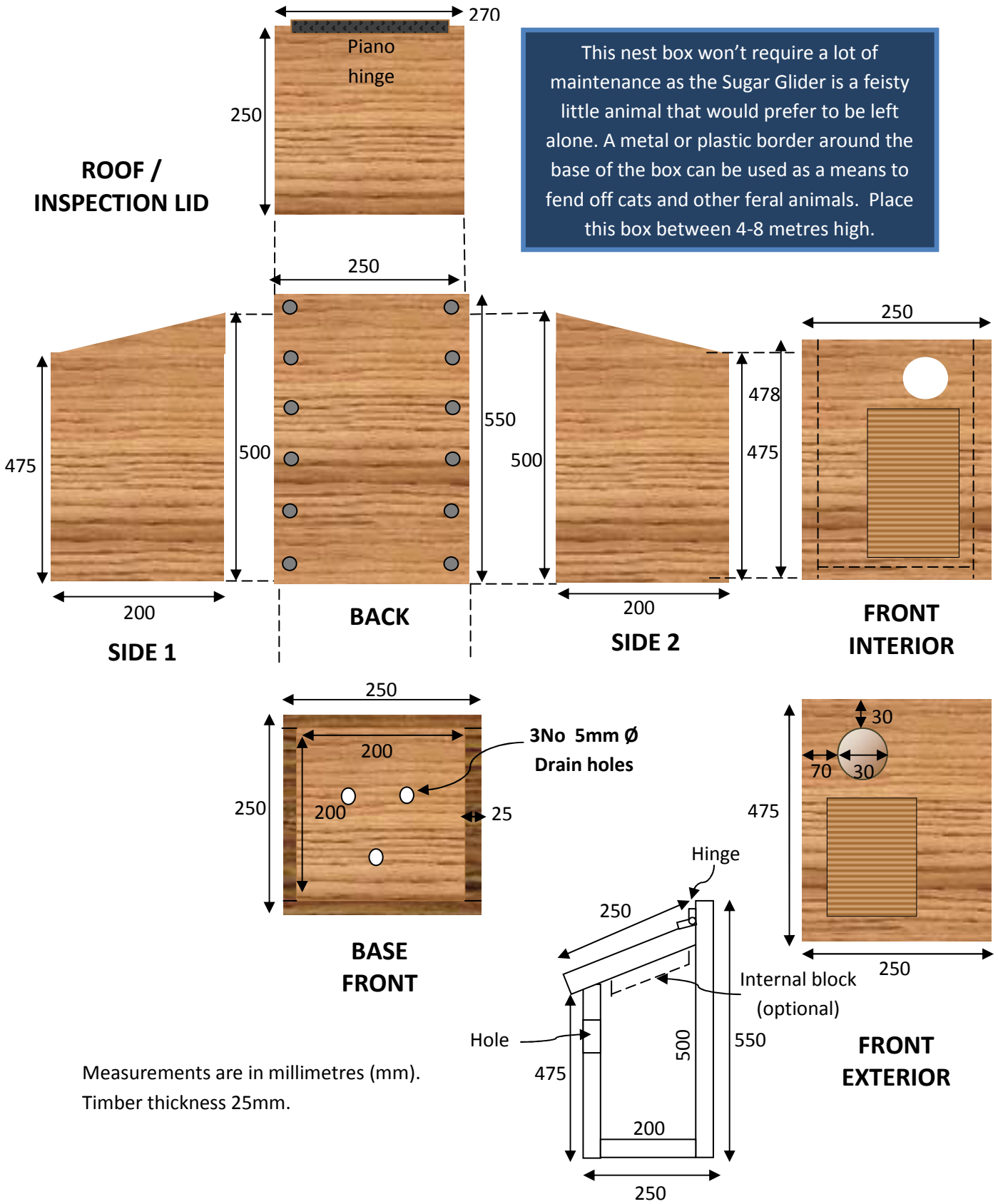

This nest box won't require a lot of maintenance as the Sugar Glider is a feisty little animal that would prefer to be left alone. A metal or plastic border around the base of the box can be used as a means to fend off cats and other feral animals. Place this box between 4-8 metres high.

Measurements are in millimetres (mm).  
Timber thickness 25mm.

**Construction**

## Tools and materials

- Timber 25mm thick. Preferably rough sawn hardwood to allow grip for birds and mammals. Additional grooves cut into the timber will assist with entry and exit. (Do not use treated pine, plywood, particle board or craft wood).
- Hole saw or jig saw for cutting entry holes.
- Hand saw or power saw to cut wood panels.
- Hammer, screwdriver, power drill .
- Sandpaper, pencil, ruler/tape measure.
- Wood screws and construction glue (exterior PVA).
- Brass hinges, button head screws.
- Sawdust and wood shavings (no chemically treated wood).
- Exterior wood filler.
- Smooth outside corners of boxes to a 2-3mm chamfer to avoid injury when handling.
- Optional: paint outside of boxes with two coats of acrylic paint in a camouflage colour eg. beige.
- Biscuit joiners to increase width of standard 100 – 150 x 25mm boards.
- **Installation method 1:**  
Galvanised strap brace 25 x 1mm with pre-punched holes for fixing boxes to tree trunks or posts.  
**OR**
- **Installation Method 2:**  
Mounting strip of timber 200mm longer than nest box height (for 100mm overhang each end) x 90mm wide, plus a smaller piece of timber to act as a spacer between mounting strip and nest box. Secure spacer in middle of back panel with glue and screws from the inside. Use glue and screws to attach mounting strip to spacer. Pre-drill a hole at the top and bottom of mounting strip.
- Galvanised screws.
- Stencil number or box type on exterior of box, preferably at base of box for reference/monitoring purposes.

**Installation**

When installing nest boxes consider the following:

- The nest box should be placed high enough to make it safe from predators but low enough to make it safe for humans to inspect and maintain. Depending on the species, nest boxes will have different requirements as to what height they are to be placed.
- The nest box should be installed in a position that will avoid prevailing winds and wet weather, especially in the winter months. Entrances should also be placed where shade can be provided, especially during summer.
- Use a ladder to secure nest boxes but make sure someone is with you. Two ladders with one person on each may be useful when installing heavy nest boxes.
- Depending on the type of nest box, some can be attached using galvanized coach screws. These are drilled through a pilot hole on the nest box. Place 25mm minimum rubber chair tip or 60mm cushion door stop between the tree and back of the nest box. Then, using an electric power drill, attach the screw so it penetrates through to the tree. (Boxes are to be placed as vertical as possible).
- Other nest boxes can be secured to trees, poles, structures or buildings depending on the species.
- Ensure that the ground below the nest box is clear of any obstacles for the secure placement of ladders needed for installation and monitoring purposes.



Installation of a bat nest box

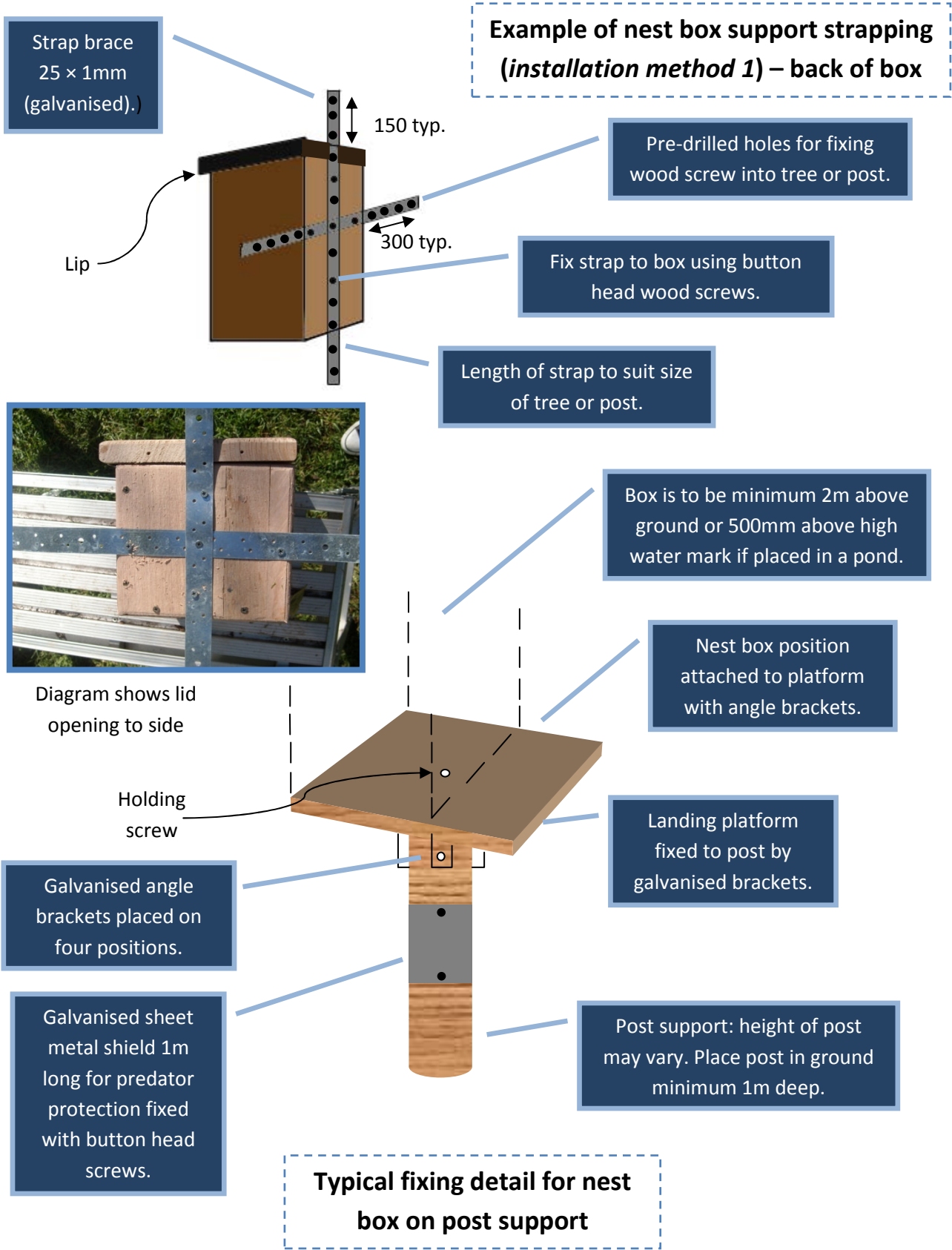

Typical nest box components

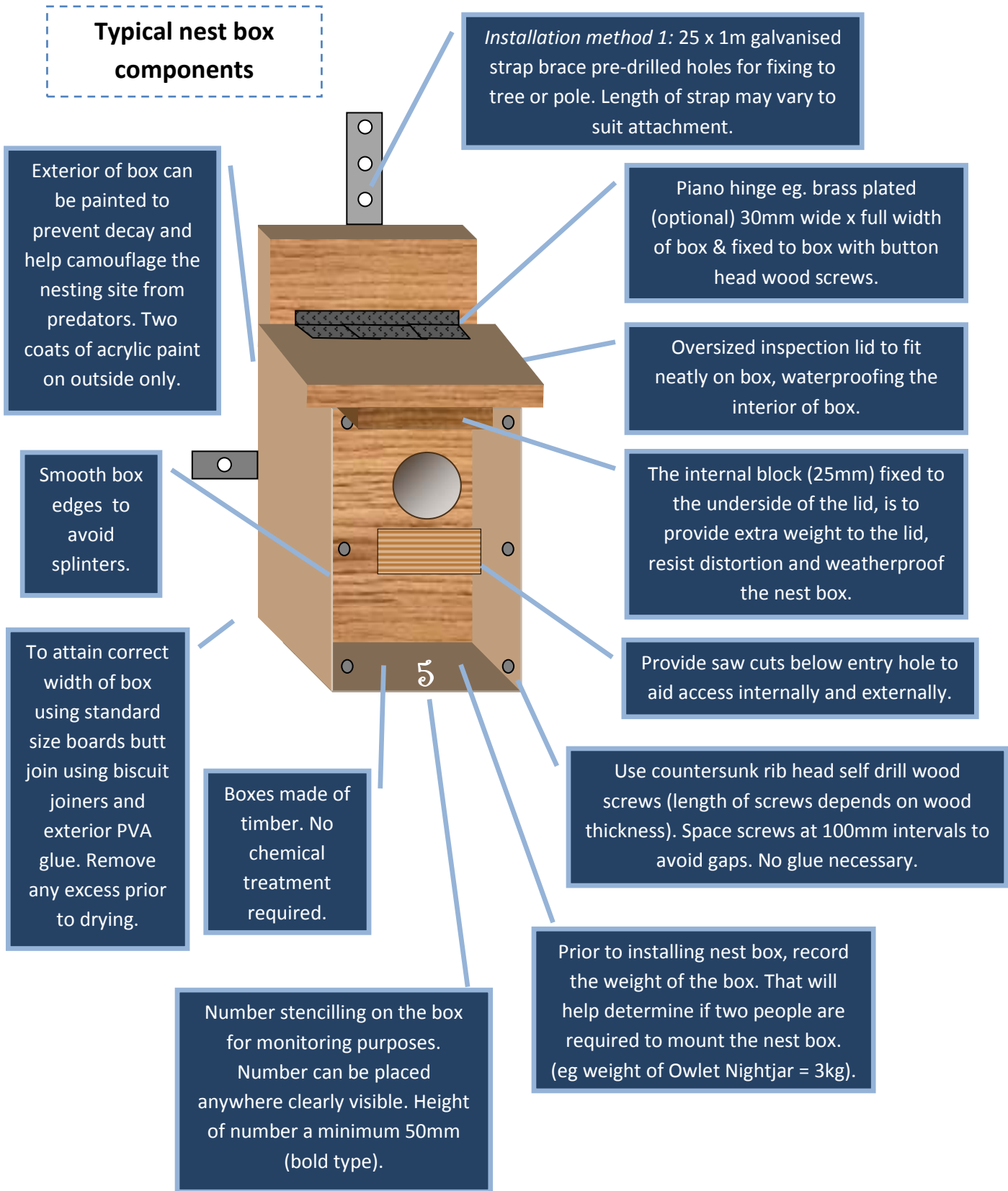



### **Maintenance**

- Maintenance aims to keep nest boxes in good condition in order to encourage native wildlife to nest. Maintenance can be conducted when monitoring boxes.
- Over time, rain may cause the timber surrounding the lid's hinge screws to rot. If the lid cannot be securely tightened then it may need to be replaced.
- Boxes may begin to split along the grain or form gaps between the joints. Use an outdoor wood filler or construction glue to repair the box.
- If the lid of the box jams, unscrew, resize and re-fit the lid.
- Make sure that any tree growth that surrounds the base entrance is cut back.
- Nest box attachment points should be checked periodically to ensure it remains secure and not causing damage to the tree.
- If native animals are nesting when the box needs repairing, try leaving the repairs to another occasion if possible.
- Nest boxes can often be invaded by mynas, sparrows, starlings and bees which may prevent or drive out native wildlife. A baffle over the front hole will discourage feral birds. If already invaded, remove their nests and eggs. If bees have invaded acquire an apiarist (bee-keeper) to remove the hive. It might be a good idea to relocate the nest box away from nectar vegetation.
- Remove cob webs, spiders and ants.

### **Monitoring**

- Monitoring aims to record the usage of nest boxes by specific native wildlife.
- When monitoring, be conscious of the sleeping, breeding and nesting patterns of specific species. For example bats will fly from their roosts soon after dusk, so monitoring needs to take place before dusk.
- If no native animal is present, check for droppings, chewing or scratch marks.
- Minimum of 3 months between inspections.



Inspecting and recording the usage of an Owlet Nightjar nest box





<b>Observer's Name:</b>				
<b>Address:</b>			<b>Ph:</b>	
<b>Date:</b>			<b>Time:</b>	
<b>Location / GPS: E:</b>			<b>N:</b>	
<b>Weather Conditions:</b>				
<b>Box Type</b>	<b>Box No</b>	<b>Internal/External Observations</b>	<b>Species Observed</b>	<b>Comments/Habitat</b>
Eg. Crimson Rosella	Eg. 10	Eg. Chew marks around entrance hole, scats etc.	Eg. Rosella sitting on lid.	Eg. Bird entered box with a mate.

**Nest box**

**Date installed:** \_\_\_\_\_

**Tree type:** \_\_\_\_\_

**Post/House/Shedding:** \_\_\_\_\_

# REFERENCES

## Pictures

- Kerle, A (2001) *'Possums: The brushtails, ringtails and greater glider'* Australian Natural History Series, UNSW Press, N.S.W
- Flegg, J (2002) *'Photographic Field Guide Birds of Australia'* (Sec ed.) New Holland Publishers
- Churchill, S (1998) *'Australian Bats'* New Holland Publishers
- Hollands, D (1999) *'Kingfishers & Kookaburras; Jewels of the Australian Bush'* Reed New Holland
- [www.google.com/images](http://www.google.com/images) (2009)
- Savin, D (1989) *'Wetlands Wildlife; The Nature of Wetlands in Southern Australia'* Gould League, Victoria
- Brunet, B (2000) *'Australian Insects: A Natural History'* New Hollands, Sydney
- Lyle, S (2006) *'Discovering Fruit & Nuts: A comprehensive guide to cultivation, uses and health benefits of over 300 food-producing plants'* Landlinks Press, Collingwood

## Pictures and information

- *'Encyclopedia of Australian Wildlife'* (1997), Readers Digest, Sydney
- <http://www.birdsinbackyards.net/> (2007)
- de Souza-Daw, R (2000) *'The Bat Roost Kit'* West Gippsland Catchment Management Authority, Latrobe Valley



